



Diamond

package sewage treatment plants for 1 - 55 people



- ✓ Compact design
- ✓ No odours
- ✓ Easy to install

The Authentic WPL Diamond

n55Plus

The WPL Diamond range of package sewage treatment plants is specifically designed for properties not connected to mains drainage, in a range of sizes for population equivalents of 1-55 persons.



The Diamond offers a range of brilliant features

• No odours

Does not require primary settlement of raw sewage, where odours can occur

• Up to 3 year de-sludge intervals

Efficient, continuous, bacterial digestion process (DMC range usually requires annual de-sludging)

• No internal moving parts

Simple design, reliable operation, minimal maintenance and low running costs

• Fantastic value for money

Low running costs, with a small air blower

• Alarm beacon included

All weather, air blower kiosk fitted with alarm beacons (+ second alarm beacon as standard for IPC models)

Process guaranteed for life



• Load tested and water tight

WPL Warranty*: Tank: 10yr Air blower: 2yr



• Compact design

Reduced excavation and handling costs

• Robust construction

No concrete backfill in some situations



• Low visual impact

Small lid, flush with the ground

• Easy to install with minimal labour

*warranty subject to regular plant maintenance

+ flexible options (additional)

1. Sample Chamber

A compact chamber designed to allow easy sampling of treated wastewater (final effluent), may be required by the Environment Agency or regulatory authority.

2. Invert Extensions



The Diamond range offers one of the widest choices for invert extensions, giving complete flexibility for different site conditions and installation requirements.

3. Integral Pump Chamber (IPC)

Has the features of the Diamond plant but with an IPC, designed to pump final effluent to a water course, ditch or soakaway, which may be on an incline, in a high water table area, or is a distance away from the soakaway. It can deliver up to 80 litres per minute of effluent at a head of 4m.



IPC access lid during installation

IPC consists of:

- 240v, 0.25kw submersible pump, integral float switch with stainless steel internals and non-return valve
- High level floatswitch and mounting tube
- High level alarm beacon with 10m lead
- Floatswitch adapter socket
- 50mm MDPE Pipe outlet
- Invert extension kit for the IPC also available (optional extra)

The Diamond Standard

We pride ourselves on the fact that the WPL Diamond meets the following standards:

- **CE Marked** fully accredited and certified under the BS EN12566-3 standard
- **Environment Agency** fully compliant with recommendations and meets normal consent standards
- **UK Building Regulations** fully compliant
- **Environmental Permitting Programme 2 (EPP2)** meets current legislation
- **British Water** designed using their Code of Practice Flows and Loads, to ensure correct sized tank
- **LABC Registered**



How does the Diamond plant work?

- The central aeration chamber (1) empties into the bottom of the outer clarifier chamber (2).
- A 200mm diameter draft tube (3) releases air through a disc plate diffuser (4).
- An upward flow of process fluid draws settled solids (5) through the draft tube to discharge at the surface of the aeration chamber.
- The design of the draft tube ensures complete mixing of oxygen with the sewage. Oxygenation allows aerobic organisms, that biologically degrade wastewater contaminants, to grow.
- Gravity causes aerated solids to settle at the tank bottom where they are drawn back up through the draft tube.
- Raw sewage displaces biological solids from the aeration chamber to the clarifier. Quiescent conditions in the clarifier allow digested solids to settle at the base and return to the aeration chamber.

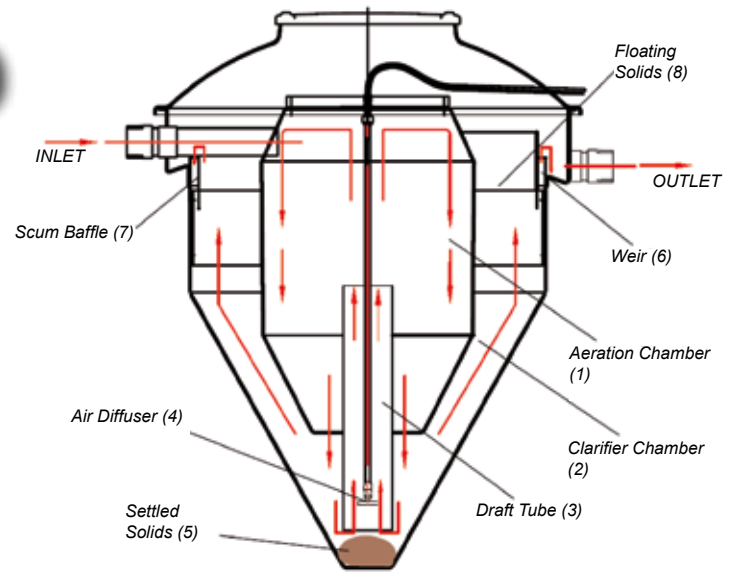

- Clarified effluent flows over the weir (6) and discharges through an outer trough to a 110mm pipe connection. The scum baffle (7) prevents solids (8) from passing over the weir.

Installation

A comprehensive installation manual is supplied with each Diamond plant, which should be read thoroughly prior to installation. The plant is easy to install and in some situations no concrete backfill is needed.

We recommend you use a qualified and experienced installer; please contact a member of the WPL Sales Team if you need help finding one.

Air Blower

The Diamond's air blower is supplied with an alarm and an enclosure to protect it from the weather.

Your plant comes complete with 10 metres of airline to connect the blower and the tank. The Diamond can accommodate longer airlines of up to 30 metres from the blower; please speak to a member of our sales team for more information.

Process Performance

The Diamond treats wastewater to a 95 percentile standard of:

- **20mg/l Biological Oxygen Demand (BOD)**
- **30mg/l Suspended Solids (SS)**
- **20mg Ammoniacal Nitrogen (AMM-N)**

If more stringent environmental requirements are specified, please contact WPL on 0845 450 4818.

Loadings (based on British Water Code of Practice) and Blower Power Rating

| Model | DMS2 | DMS3 | DMS4 | DMS5 | DMC6 | DMC7 | DMC8 | DMC9 |
|---|--|------|-------|-------|-------|--------|--------|--------|
| Population range (persons) | 1-6 | 5-11 | 10-15 | 14-20 | 21-27 | 28-35 | 36-45 | 46-55 |
| Maximum organic loading BOD/day (grams) | 360 | 660 | 900 | 1,200 | 1,620 | 2,100 | 2,700 | 3,300 |
| | A WPL/British Water Loading Guide providing further information for non-domestic applications is available | | | | | | | |
| Blower Motor Size (kw)* single phase rating | 0.12 | 0.13 | 0.17 | 0.24 | 0.55 | 0.75** | 0.75** | 0.75** |

* Actual power consumption may vary (dependent on motor efficiency and nature of installation), size stated is the motor size NOT actual power consumption

**For DMC7, DMC8 AND DMC9 models using 3 Phase electrics, blower motor is rated at 0.9 kw

Process performance is subject to strict adherence to WPL's Installation Manual, User Guide/Operation & Maintenance Manual, and a start up period of 6-12 weeks depending on plant loadings and water temperature.

Dimensions

| Model | Max Outside diameter | Height to inlet | *Inlet invert depth | Height to outlet | In ground depth | Weight empty | Total capacity |
|-------|----------------------|-----------------|---------------------|------------------|-----------------|--------------|----------------|
| DMS2 | 1.85m | 1.71m | 618mm | 1.61m | 2.34m | 154 Kg | 2,271 ltr |
| DMS3 | 2.07m | 1.84m | 770mm | 1.74m | 2.62m | 192 Kg | 3,028 ltr |
| DMS4 | 2.1m | 2.05m | 742mm | 1.93m | 2.8m | 210 Kg | 3,974 ltr |
| DMS5 | 2.1m | 2.05m | 742mm | 1.93m | 2.8m | 210 Kg | 3,974 ltr |
| DMC6 | 3.2m | 2.78m | 580mm | 2.68m | 3.35m | 380 Kg | 9,056 ltr |
| DMC7 | 3.2m | 2.78m | 580mm | 2.68m | 3.35m | 380 Kg | 9,056 ltr |
| DMC8 | 3.2m | 3.14m | 580mm | 3.04m | 3.7m | 460 Kg | 15,038 ltr |
| DMC9 | 3.2m | 3.14m | 580mm | 3.04m | 3.7m | 460 Kg | 15,038 ltr |

Deeper inverts can be accommodated with our range of standard invert extensions, contact WPL for further information. All dimensions +/- 10mm tolerance.

Other WPL Products

Wastewater Treatment



HiPAF

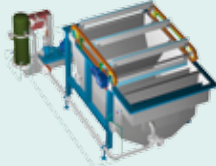

Industrial Effluent Treatment



Hire Fleet

Rainwater Harvesting



RainRetain Developers



RainRetain Domestic



RainBrain



RainSustain Commercial

Other Products & Services



Grease Guzzler

Installation and Maintenance

The Environment Agency requires all sewage treatment plants to be operated in accordance with the maintenance plan specified by the manufacturer. WPL Ltd supplies a log book with each plant, to demonstrate maintenance and desludging compliance, which must be retained for at least 5 years.

Every Diamond comes with a helpful user guide and an operation and maintenance manual, giving useful information on daily operation and periodic maintenance.

Maintenance should only be undertaken by a qualified service engineer accredited by British Water.



Call: **+44 (0)845 450 4818**
 Fax: **+44 (0)23 9224 2624**
 Click: **enquiries@wpl.co.uk**
 Web: **www.wpl.co.uk**

WPL Limited
 Units 1 & 2 Aston Road
 Waterlooville
 Hampshire PO7 7UX
 United Kingdom

Where to buy WPL products

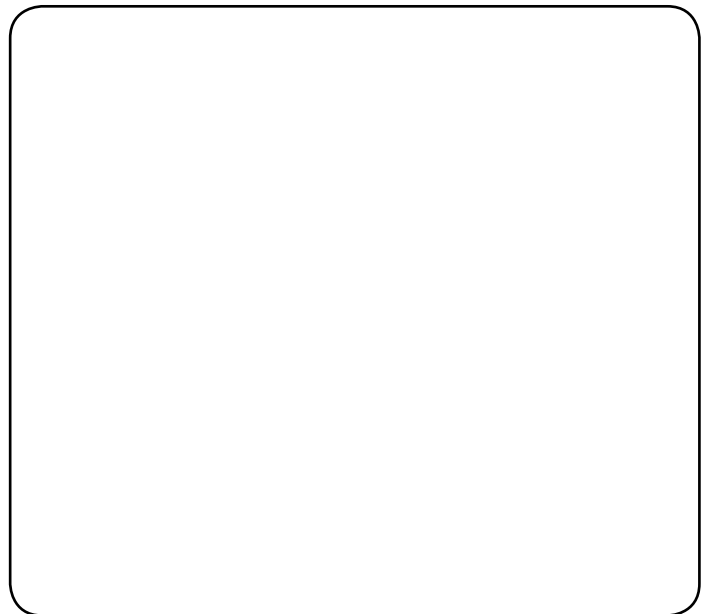

About WPL Limited

WPL Limited provides innovative and reliable wastewater treatment, rainwater harvesting and grease management systems for domestic, commercial and industrial markets as well as holding a prominent position as a supplier to the water companies. As an internationally recognised leader in the design, manufacture and supply of both standardised, and bespoke environmental solutions, WPL Limited is dedicated to ensure the provision of high quality products and services.

Environmental Policy

WPL Limited is ISO14001 accredited. WPL Limited rigorously fulfils its vision of protecting the environment by delivering reliable wastewater solutions. A strong focus on quality and compliance ensures that all wastewater treatment systems are designed to work within the guidelines of the British Water Code of Practice and exceed all present and proposed discharge consent standards enforced by the Environment Agency, SEPA and other regulatory authorities.

